

# CONTINENTAL

FORNI



---

## INDEX

---

ROTOR OVENS «INDUSTRIA» MODEL (FRONT BURNER)	3
ROTOR OVENS «CR» MODEL (BACK BURNER)	8
DECK OVENS WITH PIPES AND BURNER	13
ELECTRIC DECK OVENS	18
MODULAR DECK OVENS	23
HYBRID DECK OVENS	25
CONVECTION OVENS	29
AUTOMATIC LINES AND CUSTOMIZED SOLUTIONS	31
TRAYS, TROLLEYS, LOADERS, LIFTERS	32
CABINETS	36
SPIRAL MIXERS	38
FORK MIXER AND CUTTERS	39
DIVIDERS	40
MOULDERS	41
PLANETARY MIXERS AND DOUBLE ARM MIXERS	42
SHEETERS	43
CROISSANT GROUPS	44

---

# OVENS



## ROTOR OVEN SERIES

# INDUSTRIA MODEL

FRONT BURNER



The ROTOR INDUSTRIA model was born from the decades of experience of our technicians; it was designed and built to produce any type of bread and pastry products, even the most complicated. The oven is built with quality materials and selected electronic components, suitable for craftsmen and semi-industrial laboratories, it permits maximum versatility and allows impeccable cooking with full or half-empty trolley.



➤ PRE-ASSEMBLED STRUCTURE

- Sturdy and FULL WELDED INOX STRUCTURE;
- The oven is divided in 2 or 3 semi-assembled pieces (it depends on the model).
- Advantages:
  - Max. durability over time;
  - Absence of leaks;
  - Easy and very quick assembly on site;
  - Possibility to pass through any standard 95cm door.

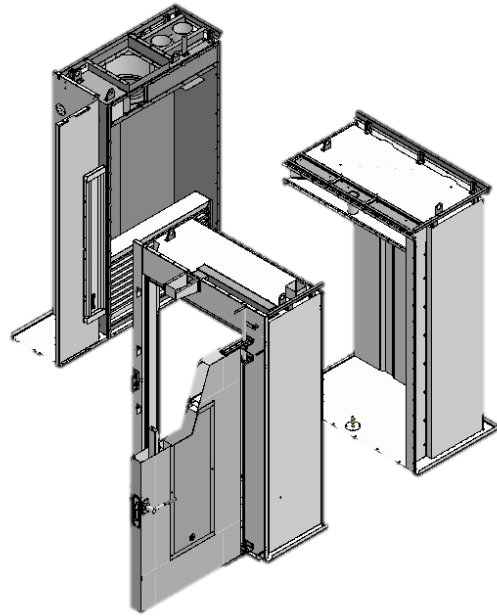

MAIN FEATURE: FRONT BURNER

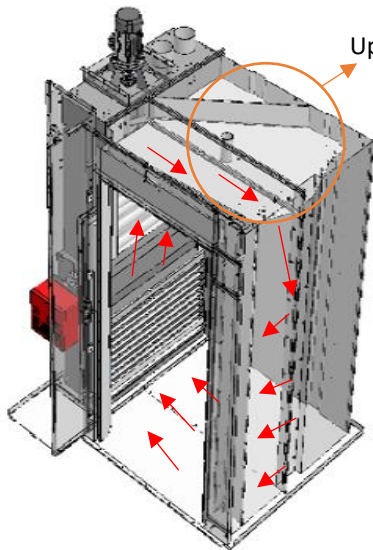

Upper cavity for a perfect air flow, from bottom to top ("GROUND" EFFECT)

➤ COOKING UNIFORMITY AND PERFECT AIR CIRCULATION

- The oven has the best possible air VERTICAL flow, from bottom to top, to reproduce the famous ground effect, typical of deck ovens, on the rotary ovens too;
- The cooking is perfectly homogeneous for each tray of the trolley and in all its parts;
- The double ascending air flow (front and rear) is regulated by slits;



VERTICAL AIR CYRCLE

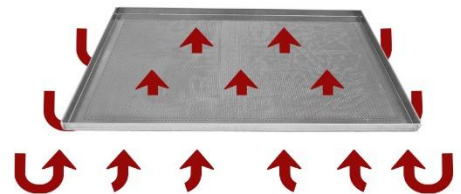

➤ MAINTENANCE AND EASY ACCESSIBILITY

- Easy frontal access to all parts needing maintenance (no needed back space behind the oven);
- The burner is positioned frontally, inside a dedicated door;
- Heat exchanger and steamer can be fully inspected thanks to the easy removal of the steel protection, directly inside the cooking chamber;
- The Rotor INDUSTRIA oven is the perfect oven for installations between 3 walls or in series with other ovens without having to lose useful working spaces.

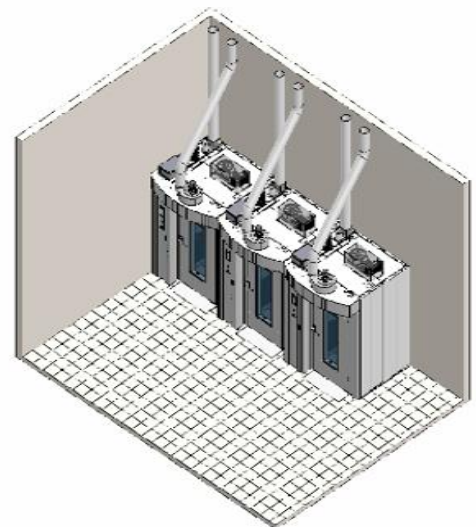

Industria «Super» has a very big heat exchanger: 1110x1030x410 mm

### ➤ INNOVATIVE HEAT GENERATOR WITH LOW CONSUMPTION

- The heat exchanger is made of aisi 310s, a special refractory steel with big thickness, resistant to high temperatures.
- Its "INVERSE" and INNOVATIVE structure allows the heat to be retained inside the heat exchanger for a longer period than any other ovens, permitting to the burner to ignite heat LESS FREQUENTLY and this allows huge energy savings;
- Numerous big size of circular-section tubes allow excellent performance.

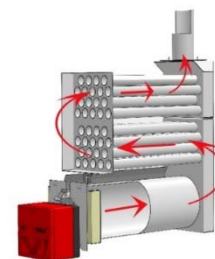
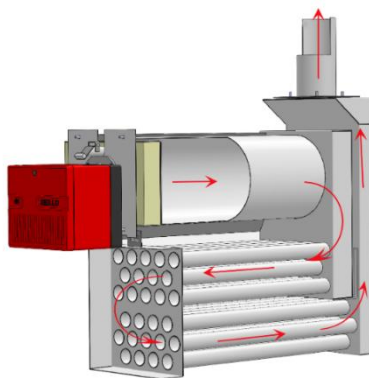

Difference with other ovens heat-exchanger:

TRADITIONAL heat exchanger has "PULL-SYSTEM" flow, directly from burner to chimney.

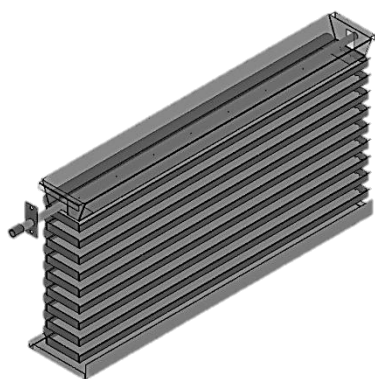

### ➤ DRAWER STEAMER: homogeneous and abundant steam every time needed.

- The powerful steamer, positioned below the heat exchanger, guarantees abundant steam production even in the presence of a continuous work cycle, rapid recovery times and homogeneous distribution over the entire trolley.
- The steamer is made up of an expansion tank and many modular elements, easy to access, with removable sections to facilitate maintenance.



Optional:  
Steamer with spheres or with mixed structure "spheres + iron bars".



### ➤ TROLLEY



- INDUSTRIA rotor oven is higher than other rotor ovens on the market and allows LARGER COOKING SURFACE with the same distance between trays. Trolley can be realized based on customer needs.
- Our trolleys have a little step on each shelf to prevent the trays from falling during handling.
- Trolleys can be produced with upper hook, platform hook or special constructions based on different needs.

➤ DOOR

- High thickness
- Satin stainless steel
- Double glass
- Internal cavity to avoid overheating
- Steel + Teflon handle
- 100% Adjustable over time
- Movement on self-lubricating brass bushings



➤ POWER SUPPLY

The burner is located in the frontal side of oven (INDUSTRIA MODEL), a perfect solution for functionality, maintenance and control.

The power supply could be:

- diesel, methane or LPG burner (1)
- armored heaters (2)
- pellet system (solid)



(1)

(2)

➤ CONTROL PANEL



ELECTROMECHANICAL



TOUCH SCREEN

Allows:

- Inverter
- Air adjustments (10 speeds)
- 100% recipe storage and data analysis
- Delicate cooking process

➤ HOOK

Rotor INDUSTRIA ovens have different types of hooks:

- Classic hook (1)
- Platform (2)
- Automatic lifting (3)
- Special / customized (4)



1



Gearmotor



2



3-4

## TECHNICAL FEATURES "INDUSTRIA"

INFO	SMART	MEDIO	SUPER
N° trolley	1	1	1
Size of trolley	40x60 50x70 45x65	45x75 60x80	60x100 80x80 80x100
N° of shelves on each trolley	12-15-18	15-18-20	16-18-20
External dim. WxD (cm) – hood excluded	145x164	170x154	205x180
H without motors (cm)	207	230	230
H with motors (cm)	246	270	270
Weight (kg)	650	1350	1800
Burner (Riello as suggested)	frontal	frontal	frontal
Thermic Power (kcal/h)	45.000	55.000	65.000
Thermic Power (KW)	52	64	76
Electric Power with Burner (KW)	2	2,5	3
Electric Power with resistances (KW)	36 (9)	48 (12)	70 (18)
Voltage (special on request)	400 v – 50hz – 3PH	400 v – 50hz – 3PH	400 v – 50hz – 3PH
Structure material (Internal – External)	inox aisi 430 - brushed	inox aisi 430 - brushed	inox aisi 430 - brushed
Manual trolley positioning	✓	✓	✓
Movements on brass bushes	✓	✓	✓
Fully welded structure	✓	✓	✓
Pre-assembled structure (n° pieces)	2	2	3
Heat Exchanger cylinders material	Aisi 310s refractory	Aisi 310s refractory	Aisi 310s refractory
Lights inside cooking chamber	✓	✓	✓
Reverse System + consumption optimization	✓	✓	✓
Position of steamer (with drawers)	Under Heat Exchanger	Under Heat Exchanger	Under Heat Exchanger
Removable drawers for easy cleaning of steamer	✓	✓	✓
Upper cavity of chamber with air flow system	✓	✓	✓
«Ground» effect during cooking	✓	✓	✓
«too-full" system (security)*	✓	✓	✓
Adjustable slits for the air flow*	4	4	4

\* "TOO-FULL" SYSTEM: to protect the regular process and safety of the operator, we have designed a vertical space, separated from the rest of the cooking chamber, with an opening and adjustable door that allows air and pressure given by the humidity of the dough to evacuate,.

\* SLITS: our slits to regulate the air flow during cooking process are made of 430 stainless steel and as high as the entire cooking chamber. The upper and lower part are adjustable every 10cm, to allow uniform cooking from the highest to the lowest tray.





# ROTOR OVEN SERIES

## CR MODEL

BACK BURNER



The CR ROTOR series is designed and built to produce any type of bread and pastry product. The oven is reliable, built with quality materials to last over time. The rear burner allows to have a compact and robust oven. The conception of its heat exchanger permits to cook with very high temperatures and for very long working cycles. It is suitable for craftsmen and semi-industrial laboratories ensuring maximum versatility and allowing impeccable cooking both at full and half trolley.



## ➤ PRE-ASSEMBLED STRUCTURE

- Sturdy and SEMI-WELDED STRUCTURE;
- The oven is supplied in 2 or 3 semi-assembled pieces (it depends on the model).
- Advantages:
  - Maximum resistance over time;
  - Absence of leaks;
  - Easy and very quick assembly on site;
  - Possibility to pass through any standard 95cm door.

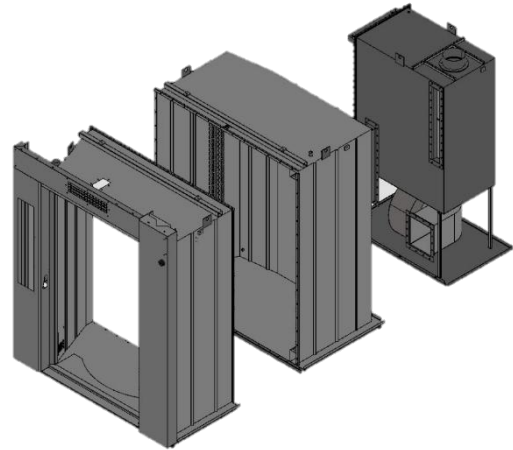

## MAIN FEATURE: BACK BURNER

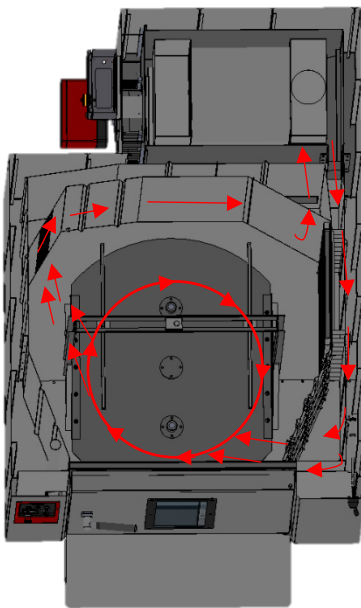

## ➤ COOKING UNIFORMITY

- The oven has air circuit designed to wrap the trolley during rotation;
- Cooking is perfectly homogeneous on each tray of the trolley an in all its parts;
- The air flow is directed by adjustable slits;
- the specially designed lateral-cavity allows the correct air flow.

## ➤ MAINTENANCE AND ACCESSIBILITY

- A lateral space must be provided for the maintenance of the back heat-exchanger;
- The burner is installed behind, on the left side;
- The glass can be removed for easier cleaning;
- The steamer is installed inside the chamber, for all its height.



## ➤ HEAT EXCHANGER

- The heat exchanger is made of high-thickness refractory steel, resistant to high temperatures and equipped with special "wings" for slow transmission and retention of heat;
- Its «DIRECT» structure allows the quick passage of heat through the pipes, even at maximum power, at high temperatures and for very long periods of time;
- The high number and size of the circular section tubes allow excellent performance.

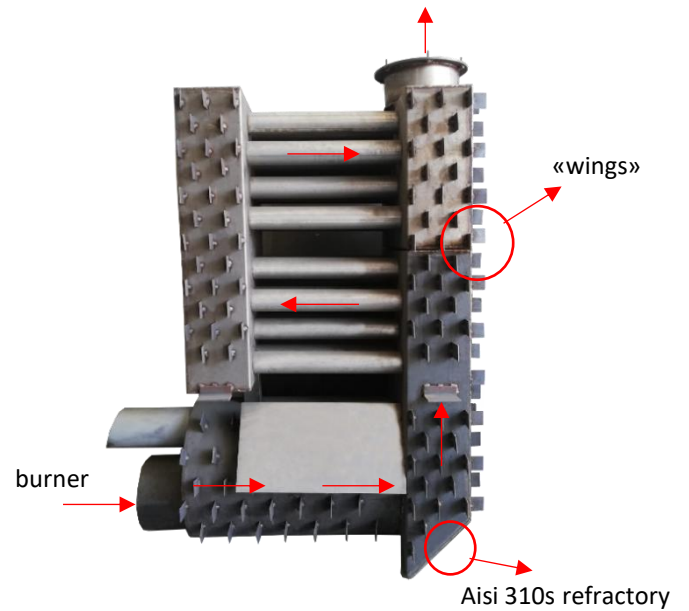
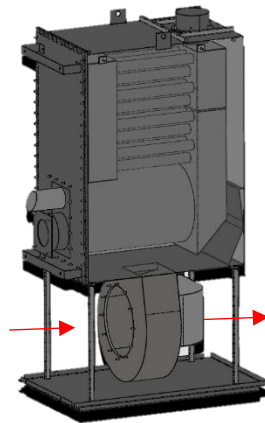

The fan pushes the hot air up to the steamer and sucks-in the hot air coming from the combustion chamber.

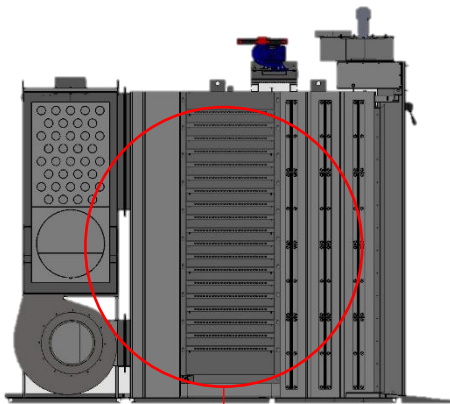

## ➤ STEAMER

- The powerful steamer, positioned inside the chamber, covers the entire wall for its entire height and guarantees abundant steam production even in the presence of a continuous working cycle, rapid recovery times and homogeneous steam distribution through the trolley;
- The steamer is made with a very strong pocket-column and allows the insertion of both standard iron bars and the famous cast iron spheres;

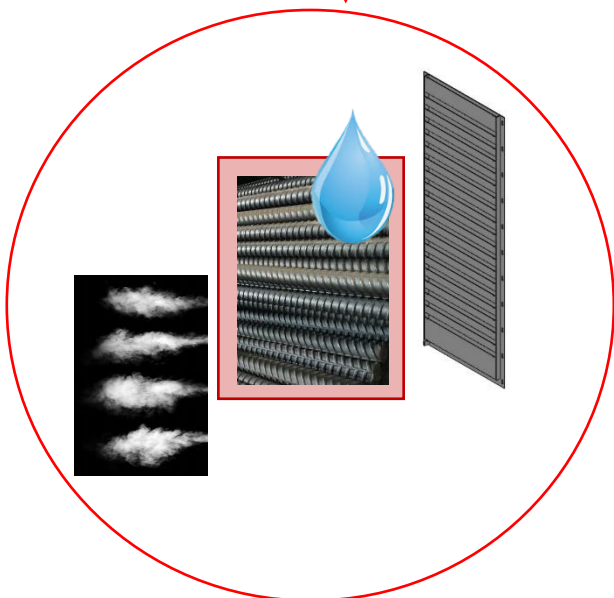

Optional:  
Steamer with spheres or with mixed structure "spheres + iron bars".



➤ DOOR

- High thickness
- Satin stainless steel
- Double glass
- Adjustable rotation pin



➤ POWER SUPPLY

CR ovens have rear burner on the left side.

The power supply can be:

- Diesel, methane or LPG burner (1)
- Armored heaters (2)
- Pellet system



(1)

(2)

➤ CONTROL PANEL



ELECTROMECHANICAL



TOUCH SCREEN Allows:

- Inverter
- air adjustments (10 speeds)
- 100% recipe storage and data analysis

➤ HOOK

CR rotor ovens have different types of hooking:

- Classic hook (1)
- Platform (2)



gearmotor



1

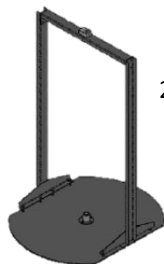

2



## TECHNICAL FEATURES «CR»

INFO	«CR» MODELS			
	CR1	CR2	CR3	CR4
N° trolley	1	1	1	2
Size of trolleys	40x60 50x70 45x65	45x75 60x80	60x100 80x80 80x100	2 X 60X80 1 X 80X120
N° of shelves on each trolley	12/18	16/18	16/18	16/18
External measures LxD (cm)	100x150	131x195	160x230	195X315
H without motors (cm)	205	240	240	240
H with motors (cm)	240	270	270	270
Weight (kg)	800	1150	1400	1800
Burner	back	back	back	back
Thermic Power (kcal/h)	40.000	55.000	80.000	90.000
Thermic Power (KW)	47	76	93	105
Electric Power with Burner (KW)	1	2,5	3	3
Electric Power with resistances (KW)	24 (6)	47 (12)	59 (18)	70 (18)
Voltage (different on request)	400 v – 50hz – 3PH	400 v – 50hz – 3PH	400 v – 50hz – 3PH	400 v – 50hz – 3PH
Structure material (Internal – External)	inox 430 - brushed	inox 430 - brushed	inox 430 brushed	inox 430 brushed
Manual trolley positioning	✓	✓	✓	✓
Movements on brass bushes	✓	✓	✓	✓
Welded structure	partial	partial	partial	partial
Pre-assembled structure (pieces)	2	3	3	3
Heat Exchanger cylinder material	310s refractory	310s refractory	310s refractory	310s refractory
Lighting	chamber	door	door	door
Direct Heat-Exchanger	✓	✓	✓	✓
Steamer	Fixed	Fixed	Fixed	Fixed
Horizontal air flow during cooking	✓	✓	✓	✓
«too-full" system as standard (security)*	✓	✓	✓	✓
Adjustable slits for the air flow*	2	3	3	3

\* "TOO-FULL" SYSTEM: to protect the regular process and safety of the operator, we have designed a vertical space, separated from the rest of the cooking chamber, with an opening and adjustable door that allows air and pressure given by the humidity of the dough to evacuate,.

\* SLITS: our slits to regulate the air flow during cooking process are made of 430 stainless steel and as high as the entire cooking chamber. The upper and lower part are adjustable every 10cm, to allow uniform cooking from the highest to the lowest tray.



# DECK OVEN SERIES

## VAPOR MODEL



The VAPOR series of deck ovens is designed and built to produce any type of bread, especially big chunky bread. The oven is extremely reliable, built with quality materials and designed as the best ovens of the past, to ensure the perfect combination of traditional cooking and innovative research of materials. It is suitable for artisans and semi-industrial laboratories, it guarantees maximum versatility with impeccable cooking of both fresh and frozen items, both at full and half load.

MAIN FEATURE: BIG ANULAR PIPES AROUND CHAMBERS – CEMENT STRUCTURE





### ➤ RING TUBES and QUALITY CONTROL

- The tubes are in Fe steel, diameter 35mm (or 27mm as optional), thickness 5.5mm.
- Each tube is manually welded to guarantee a perfect durability over time.
- The tightness of the pipe is tested by a special machine up to 600 atmospheres.
- High thickness tubes are the best choice to keep heat inside the oven as much as possible, avoiding falling down of temperature even after hours of stop.

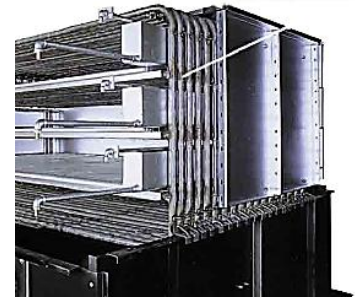

### ➤ BASEMENT

- The base of VAPOR oven is the supporting base of all the structure.
- We use high thick iron, combined with sturdy and continuous welding, to guarantee maximum durability.
- The channels for the gas passage are entirely covered with refractory bricks made according to our exclusive recipe.
- The base is designed to be extremely easy to assemble, to save as much time as possible during assembly.

MAIN FEATURE: TUBES DIAM. 35mm, THICKNESS 5.5mm

### ➤ DECKS AND COOKING

- Each tube is placed at a specific distance from each other, to ensure perfect cooking.
- The resulting step comes from years of study and experience and it is the secret of the entire structure.
- On each level outlined by the pipes, specific refractory bricks are placed to transfer the heat directly to the dough.
- The maximum recommended cooking temperature is about 300°C. Over this threshold, the safety thermostat will stop the system.
- The oven increases its temperature by about 5°C every minute and in the morning, from cold starting, it takes about 50 minutes to reach the desired temperature. High thickness tubes permit then to not fall temperature anymore

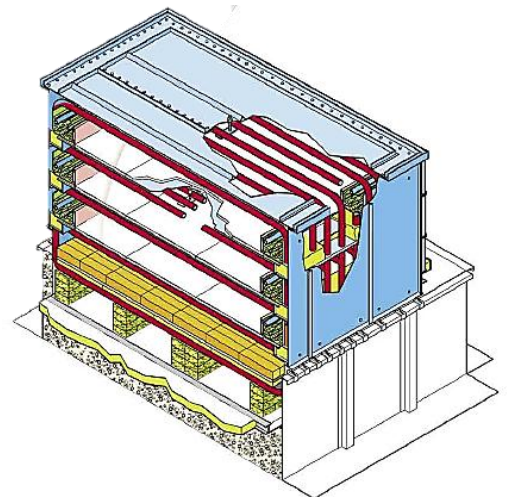

Our BRICKS are made with a specific and exclusive recipe, the result of years of experience, to ensure maximum heat retention with minimum dissipated energy. The advantage of this choice can be found in the reduction in consumption during the cooking cycle and in the constant uniformity of color of the resulting bread.

## ➤ STEAMER

- Each chamber is equipped with 2 internal steel steamers (right and left).
- They are completely independent and guarantee a high and constant steam production;
- Each steamer is easily removable for maintenance when and if necessary;
- The amount of steam produced by the steam generators is related to the temperature used in the oven. If an average temperature of about 240 °C is used, steam can be obtained for about 5 continuous seconds.

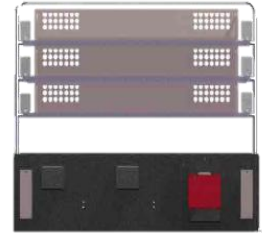
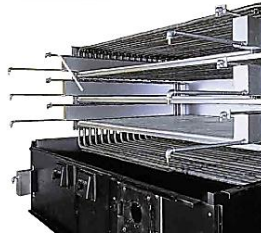

## ➤ GLASSES AND DOORS

Each oven can be customized with the number, type and size of doors.

- Available sizes: 615mm 750mm;
- Available materials:
  - ✓ glass with double chamber 20mm
  - ✓ Aisi 430 or 304 steel
- The opening can be upwards or downwards, depending on the model chosen.
- Each door is perfectly balanced.



### CONTROL PANEL:

- Standard electromechanical
- Touch screen on request

Power 24V



### POWER SUPPLY:

- Gas / oil burner
- Wood
- Pellets



### OPTIONAL:

- Lateral furnace for wood

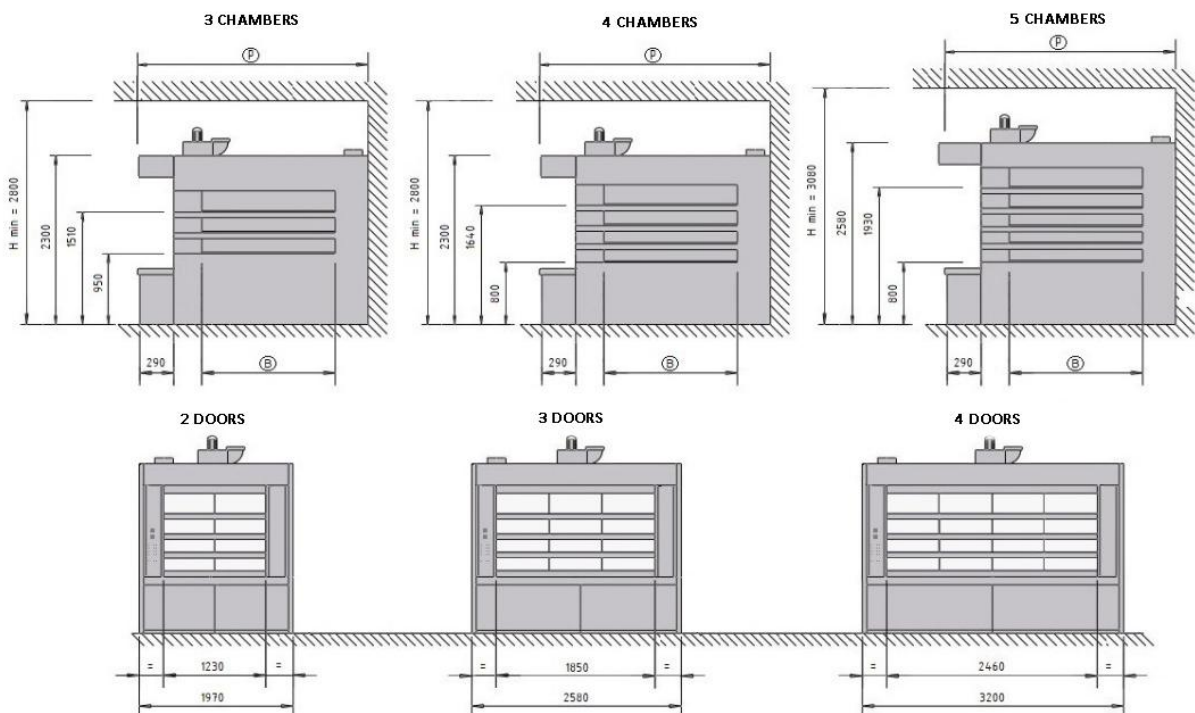



## TECHNICAL FEATURES «VAPOR»

INFO	3 CHAMBERS DECK OVENS WITH PIPES										
	36P1	36P2	36P3	39T0	39T1	39T2	39T3	312T0	312T1	312T3	312P1
N° chambers	3	3	3	3	3	3	3	3	3	3	3
N° sections	2	2	2	3	3	3	3	4	4	4	4
Cooking surface (m2)	6	7,5	9	9	10	11,2	13,4	12	14,8	17,8	20,7
Fully welded structure	✓	✓	✓	✓	✓	✓	✓	✓	✓	✓	✓
Total n° doors 62 (cm)	6	6	6	9	9	9	9	12	12	12	12
N° doors for chamber	2	2	2	3	3	3	3	4	4	4	4
Internal chamber size WxD (cm)	123x160	123x200	123x240	185x160	185x180	185x200	185x240	246x160	246x200	246x240	246x280
H 1° - 2° chamber (cm)	18	18	18	18	18	18	18	18	18	18	18
H 3° chamber (cm)	19	19	19	19	19	19	19	19	19	19	19
Door opening (versus)	down	down	down	down	down	down	down	down	down	down	down
External size WxD (cm)	197x299	197x339	197x379	258x299	258x319	258x339	258x379	320x299	320x339	320x379	320x419
H tot no motors (cm)	230	230	230	230	230	230	230	230	230	230	230
H tot with motors (cm)	260	260	260	260	260	260	260	260	260	260	260
Approx weight (kg)	6.600	7.500	8.000	8.200	8.800	9.300	10.200	9.600	10.700	11.800	13.300
Tubes diameter (mm)	35x5,5	35x5,5	35x5,5	35x5,5	35x5,5	35x5,5	35x5,5	35x5,5	35x5,5	35x5,5	35x5,5
Thermal Power kcal/h	55.000	60.000	65.000	70.000	75.000	80.000	85.000	80.000	85.000	100.000	110.000
Thermal Power KW	64	70	76	81	87	93	99	93	99	116	128
Voltage 400v 50hz 3ph	✓	✓	✓	✓	✓	✓	✓	✓	✓	✓	✓
Clay Refractory decks	✓	✓	✓	✓	✓	✓	✓	✓	✓	✓	✓
Structure material	Inox 430	Inox 430	Inox 430	Inox 430	Inox 430	Inox 430	Inox 430	Inox 430	Inox 430	Inox 430	Inox 430
Basement material	Iron	Iron	Iron	Iron	Iron	Iron	Iron	Iron	Iron	Iron	Iron
Structure with cement	✓	✓	✓	✓	✓	✓	✓	✓	✓	✓	✓
Pressed rock whool	✓	✓	✓	✓	✓	✓	✓	✓	✓	✓	✓
Tempered glass	✓	✓	✓	✓	✓	✓	✓	✓	✓	✓	✓
Chamber lighting	✓	✓	✓	✓	✓	✓	✓	✓	✓	✓	✓
Removable steamer	✓	✓	✓	✓	✓	✓	✓	✓	✓	✓	✓
Steamer per chamber	2	2	2	2	2	2	2	2	2	2	2

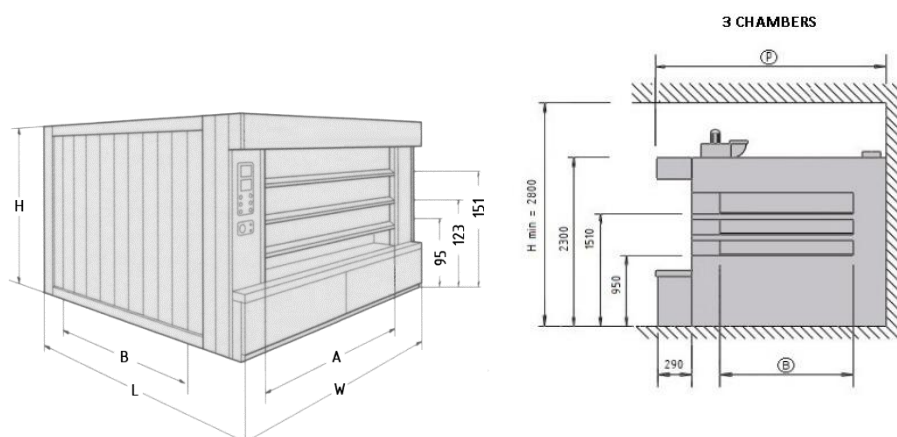

## TECHNICAL FEATURES «VAPOR»

INFO	4 CHAMBERS DECK OVENS WITH PIPES										
	48P0	48P2	48P3	412T1	412T2	412T3	412P1	416T2	416T3	416P1	416P2
N° chambers	4	4	4	4	4	4	4	4	4	4	4
N° sections	2	2	2	3	3	3	3	4	4	4	4
Cooking surface (m2)	8	10	11,9	11,9	14,9	17,8	20,8	19,7	23,7	27,6	29,6
Fully welded structure	✓	✓	✓	✓	✓	✓	✓	✓	✓	✓	✓
Total n° doors 62 (cm)	8	8	8	12	12	12	12	16	16	16	16
N° doors for chamber	2	2	2	3	3	3	3	4	4	4	4
Int. chamber WxD (cm)	123x160	123x200	123x240	185x160	185x200	185x240	185x280	246x200	246x240	246x280	246x300
H 1° e 2° chamber (cm)	18	18	18	18	18	18	18	18	18	18	18
H 3° chamber (cm)	19	19	19	19	19	19	19	19	19	19	19
Door opening (versus)	down	down	down	down	down	down	down	down	down	down	down
External size WxD (cm)	197x299	197x339	197x379	258x299	258x339	258x379	258x419	320x339	320x379	320x419	320x439
H tot no motors (cm)	230	230	230	230	230	230	230	230	230	230	230
H tot with motors (cm)	260	260	260	260	260	260	260	260	260	260	260
Approx weight (kg)	6.600	7.500	8.000	9.000	9.600	10.500	11.700	9.600	10.700	11.800	13.300
Tubes diameter (mm)	35x5,5	35x5,5	35x5,5	35x5,5	35x5,5	35x5,5	35x5,5	35x5,5	35x5,5	35x5,5	35x5,5
Thermal Power kcal/h	60.000	75.000	80.000	85.000	95.000	100.000	110.000	110.000	115.000	120.000	130.000
Thermal Power KW	70	87	93	99	110	116	128	128	134	139	151
Voltage 400v 50hz 3ph	✓	✓	✓	✓	✓	✓	✓	✓	✓	✓	✓
Clay Refractory decks	✓	✓	✓	✓	✓	✓	✓	✓	✓	✓	✓
Structure material	Inox 430	Inox 430	Inox 430	Inox 430	Inox 430	Inox 430	Inox 430	Inox 430	Inox 430	Inox 430	Inox 430
Basement material	Iron	Iron	Iron	Iron	Iron	Iron	Iron	Iron	Iron	Iron	Iron
Structure with cement	✓	✓	✓	✓	✓	✓	✓	✓	✓	✓	✓
Pressed rock whool	✓	✓	✓	✓	✓	✓	✓	✓	✓	✓	✓
Tempered glass	✓	✓	✓	✓	✓	✓	✓	✓	✓	✓	✓
Chamber lighting	✓	✓	✓	✓	✓	✓	✓	✓	✓	✓	✓
Removable steamer	✓	✓	✓	✓	✓	✓	✓	✓	✓	✓	✓
Steamer per chamber	2	2	2	2	2	2	2	2	2	2	2

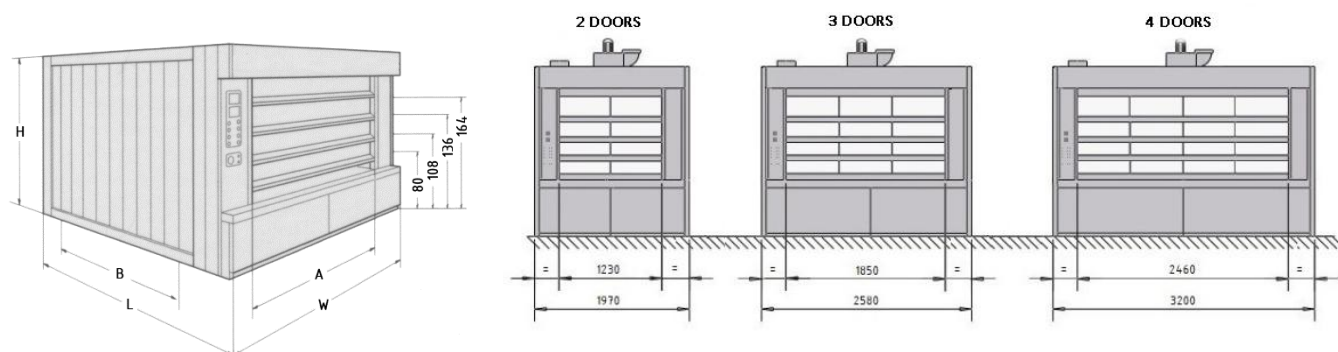

5° cooking chamber on demand

# DECK OVEN SERIES

## ELECTRO MODEL



Energy  
saving

The ELECTRO deck oven series was born, designed and built to produce any type of bread, taking all the advantages of armored electric elements power supply and low energy consumption.

MAIN FEATURE: ELECTRIC RESISTORS POWER SUPPLY



## ➤ BASEMENT AND STRUCTURE

- The base of an ELECTRO oven is the support of all the structure.
- We use high thick iron, combined with sturdy and continuous welding, to guarantee the maximum durability.
- The steamers are placed in the lower part of the structure directly.
- The base is designed to be extremely easy to assemble, to save the assembly time as much as possible.

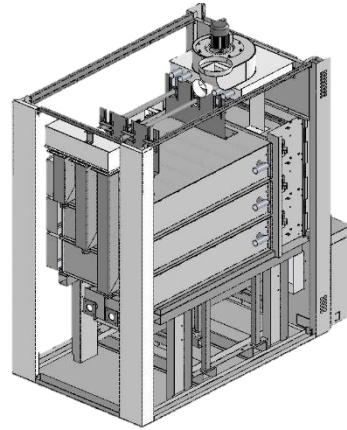

## ➤ COOKING CHAMBER

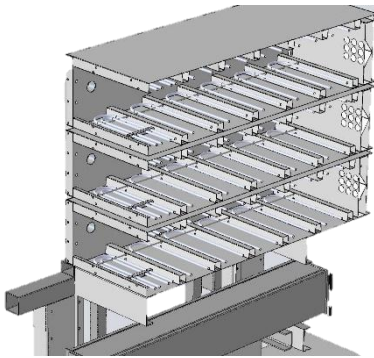

- The cooking chambers of CONTINENTAL FORNI ovens are individually assembled and hermetically constructed to prevent heat loss, even after years.
- Each chamber is independent from the others, both in terms of operation and temperature regulation.
- Each chamber is insulated with pressed rock wool, both between one and the other, and laterally; in this way it is possible to cook products that require very different temperatures even in adjacent chambers.
- The temperature of each chamber can be individually adjusted in the different areas: front, back, center.

## ➤ STEAMER

- Each chamber is equipped with 1 corresponding steamer.
- They are completely independent and guarantee a high and constant steam production thanks to the 2 armored heating elements (1kw) placed in each of them;
- Each steamer can be easily inspected for maintenance when and if necessary;
- The quantity of steam produced by the steam generators is independent of the temperature used in the oven.

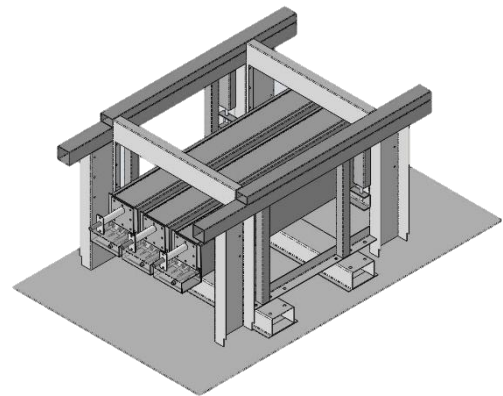

## ➤ HEATING ELEMENTS AND POWER BOARDS

- The "U" heating elements are produced in INCOLOY material.
- 2 armored heating elements for each steamer to never leave the baker without steam, even in case of breakdowns.
- The heating elements are extremely easy to replace
- Each oven is equipped with power boards
- Possibility of adding the ECO-system for further energy savings.
- Possibility to control the oven with Touch Screen control panel on request.

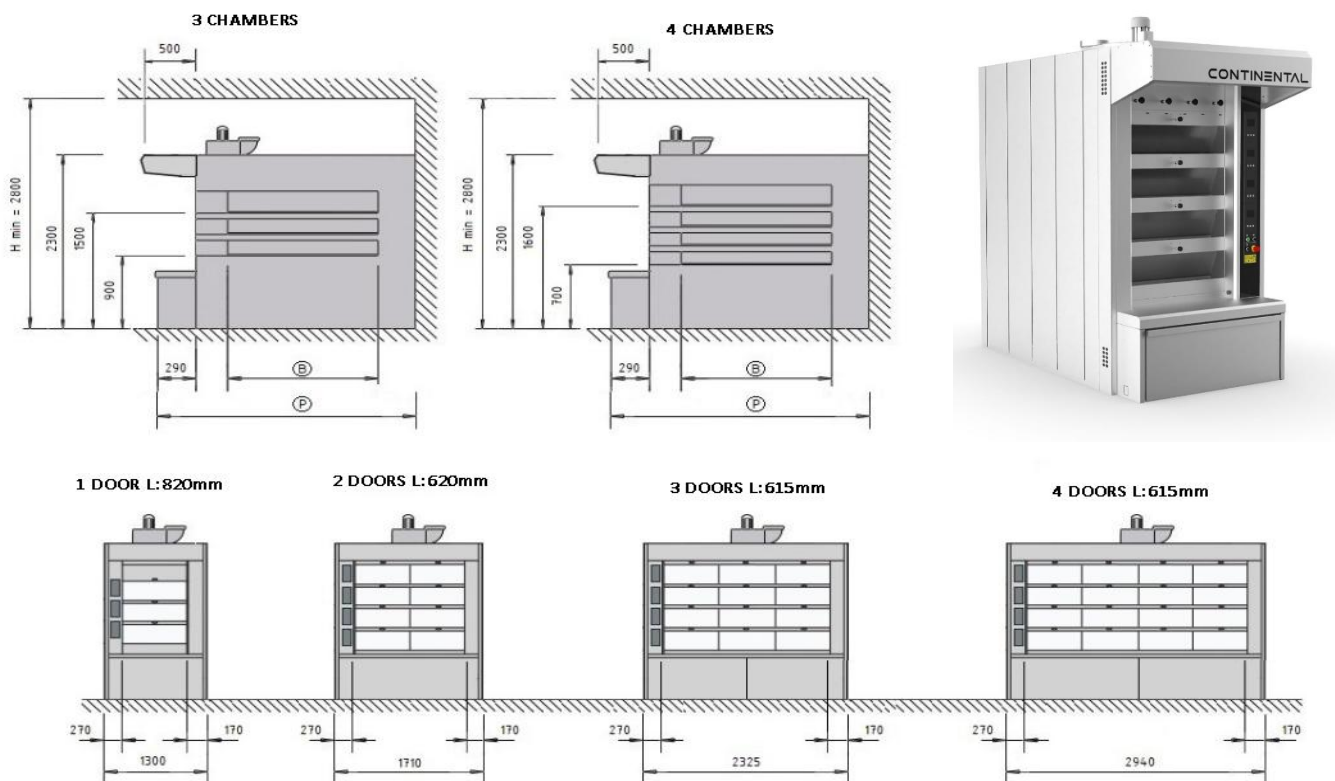

➤ ENERGY SAVING AND RESPECT FOR THE ENVIRONMENT



Continental Forni electric ovens have been conceived, designed and built to reduce energy consumption to a minimum, both in the basic version of the various models and, even more, with the application of the "ECO" system, developed to reduce even more the energy requirements for the operation of the oven.

Our ovens comply with all regulations regarding the reduction of emissions and are suitable for installation in residential areas where the installation of gas / diesel ovens is not permitted.

All our production processes are designed in order to respect the environment and not disperse more than necessary into the atmosphere.

We try not to use superfluous packaging and each staff member in the company carries out a scrupulous separate collection.

These are our main proposal and we try to apply them everywhere, both in the production departments and in our customers' laboratories.



## TECHNICAL FEATURES «ELECTRO»

INFO	ELECTRIC DECK OVEN - 1 DOOR				ELECTRIC DECK OVEN - 2 DOORS				
	4C1P12	4C1P16	4C1P18	4C1P20	408-E0	408-E1	408-E2	408-E3	408-E4
N° chambers	4	4	4	4	4	4	4	4	4
N° sections	1	1	1	1	2	2	2	2	2
Cooking surface (m2)	4	5	6	6,4	6	8	9	10,5	12
N° doors	4 x 82cm	4 x 82cm	4 x 82cm	4 x 82cm	8 x 62cm	8 x 62cm	8 x 62cm	8 x 62cm	8 x 62cm
N° doors for chamber	1 x 82cm	1 x 82cm	1 x 82cm	1 x 82cm	2 x 62cm	2 x 62cm	2 x 62cm	2 x 62cm	2 x 62cm
Int. Chamber size. WxD (cm)	82x120	82x160	82x180	82x200	123x120	123x160	123x180	123x200	123x240
H 1° e 2° chamber (cm)	18	18	18	18	18	18	18	18	18
H 3° chamber (cm)	19	19	19	19	19	19	19	19	19
Doors opening (versus)	upward	upward	upward	upward	upward	upward	upward	upward	upward
External size WxD (cm)	130x240	130x280	130x300	130x320	171x240	171x280	171x300	171x320	171x369
H tot no motors (cm)	230	230	230	230	230	230	230	230	230
H tot with motors (cm)	260	260	260	260	260	260	260	260	260
Heat armored elements	✓	✓	✓	✓	✓	✓	✓	✓	✓
Electric power installed (kw)	22	27	30	32	27,3	33,8	30	36	44,8
Power with eco system (kw)	18	22	24	27	22	27,6	24	29	36
Steamer consump. included	✓	✓	✓	✓	✓	✓	✓	✓	✓
Voltage 400v 50hz 3PH	✓	✓	✓	✓	✓	✓	✓	✓	✓
Clay refractory decks	✓	✓	✓	✓	✓	✓	✓	✓	✓
Structure material	Inox 430	Inox 430	Inox 430	Inox 430	Inox 430	Inox 430	Inox 430	Inox 430	Inox 430
Basement material	Iron	Iron	Iron	Iron	Iron	Iron	Iron	Iron	Iron
100% Independent chambers	✓	✓	✓	✓	✓	✓	✓	✓	✓
Tempered glass	✓	✓	✓	✓	✓	✓	✓	✓	✓
Chamber lighting	✓	✓	✓	✓	✓	✓	✓	✓	✓
Extractor fan in the hood	✓	✓	✓	✓	✓	✓	✓	✓	✓
Steamer for each chamber	1	1	1	1	1	1	1	1	1
Easily removable steamer	✓	✓	✓	✓	✓	✓	✓	✓	✓
Steam quantity	high	high	high	high	high	high	high	high	high
Automatic ignition	Optional	Optional	Optional	Optional	Optional	Optional	Optional	Optional	Optional
Eco system	Optional	Optional	Optional	Optional	Optional	Optional	Optional	Optional	Optional

3-5 chambers oven as «option» on demand

## TECHNICAL FEATURES «ELECTRO»

INFO	ELECTRIC DECK OVENS WITH 3 DOORS									
	309-E0	309-E1	309-E2	309-E3	309-E4	412-E0	412-E1	412-E2	412-E3	412-E4
N° chambers	3	3	3	3	3	4	4	4	4	4
N° sections	3	3	3	3	3	3	3	3	3	3
Cooking surface (m2)	6,7	9	10	12	13,4	9	12	13,4	15	18
N° doors 82 (cm)	9	9	9	9	9	12	12	12	12	12
N° doors for chamber	3	3	3	3	3	3	3	3	3	3
Internal Chamber size. (cm)	185X120	185x160	185x180	185x200	185x240	185x120	185x160	185x180	185X200	185X240
H 1° e 2° chamber (cm)	18	18	18	18	18	18	18	18	18	18
H 3° chamber (cm)	19	19	19	19	19	19	19	19	19	19
Doors opening (versus)	Upward	Upward	Upward	Upward	Upward	Upward	Upward	Upward	Upward	Upward
External size LxD (cm)	233x240	233x280	233x300	233x320	233x360	233x240	233x280	233x300	233X320	233X369
H tot no motors (cm)	230	230	230	230	230	230	230	230	230	230
H tot with motors (cm)	260	260	260	260	260	260	260	260	260	260
Armored heat elements	✓	✓	✓	✓	✓	✓	✓	✓	✓	✓
Electric power installed (kw)	28,5	35,4	33,5	38,4	49	38	47,2	44	50,8	65,6
Power with eco system (kw)	23,2	29	27	31,8	39	31	38,5	35	41	51
Steamer consump. included	✓	✓	✓	✓	✓	✓	✓	✓	✓	✓
Voltage 400v 50hz 3PH	✓	✓	✓	✓	✓	✓	✓	✓	✓	✓
Clay refractory decks	✓	✓	✓	✓	✓	✓	✓	✓	✓	✓
Structure material	Inox 430	Inox 430	Inox 430	Inox 430	Inox 430	Inox 430	Inox 430	Inox 430	Inox 430	Inox 430
Basement material	Iron	Iron	Iron	Iron	Iron	Iron	Iron	Iron	Iron	Iron
100% Independent chambers	✓	✓	✓	✓	✓	✓	✓	✓	✓	✓
Tempered glass	✓	✓	✓	✓	✓	✓	✓	✓	✓	✓
Chamber lighting	✓	✓	✓	✓	✓	✓	✓	✓	✓	✓
Extractor fan in the hood	✓	✓	✓	✓	✓	✓	✓	✓	✓	✓
Steamer for each chamber	1	1	1	1	1	1	1	1	1	1
Easily removable steamer	✓	✓	✓	✓	✓	✓	✓	✓	✓	✓
Steam quantity	high	high	high	high	high	high	high	high	high	high
Automatic ignition	Optional	Optional	Optional	Optional	Optional	Optional	Optional	Optional	Optional	Optional
Eco system	Optional	Optional	Optional	Optional	Optional	Optional	Optional	Optional	Optional	Optional

3-5 chambers oven as «option» on demand

# DECK OVEN SERIE

## MODULAR MODEL



The MODULAR modular oven series was born, designed and built to produce any type of pizza, bread, pastry taking all the advantages of armored electric elements power supply, low energy consumption and modular structure. Especially this modular composition is perfect to allow to build oven based on customer needs.

MAIN FEATURE: MODULAR STRUCTURE AND ELECTRIC RESISTORS POWER SUPPLY





## TECHNICAL FEATURES «MODULAR»

INFO	MP218	MP226	MP318	MP326	MP418	MP426	MP618	MP626
Suitable for bread, pastry, pizza	✓	✓	✓	✓	✓	✓	✓	✓
modular / stackable chambers	✓	✓	✓	✓	✓	✓	✓	✓
External Size (LxDxH) cm	125x101x36	125x101x44	166x101x36	166x101x44	125x161x36	125x161x44	166x161x36	166x161x44
Internal Size (LxDxH) cm	83x66x18	83x66x26	124x66x18	124x66x26	83x126x18	83x126x26	124x126x18	124x126x26
Weight (kg)	135	155	182	207	201	223	278	311
Nominal Power (kw)	6	6	7,8	7,8	10	10	17	17
Average Power during working	3	3	3,9	3,9	5	5	8,5	8,5
Max Temperature (°C)	400	400	400	400	400	400	400	400
N° of trays 40x60 cm	2	2	3	3	4	4	6	6
N° of Pizza diam 33 cm	3	3	5	5	6	6	9	9
Manual Loading belt	optional	optional	optional	optional	optional	optional	optional	optional
Steamer	optional	optional	optional	optional	optional	optional	optional	optional
Refractory deck floor	optional	optional	optional	optional	optional	optional	optional	optional
Embossing metal deck floor	optional	optional	optional	optional	optional	optional	optional	optional
Hood with suction fan	✓	✓	✓	✓	✓	✓	✓	✓
Proofing cabinet below	optional	optional	optional	optional	optional	optional	optional	optional
Basement with wheels	✓	✓	✓	✓	✓	✓	✓	✓
Option: shelves for basement	optional	optional	optional	optional	optional	optional	optional	optional
Power: 400v, 50hz, 3ph	✓	✓	✓	✓	✓	✓	✓	✓



# DECK OVEN SERIES

## ELECTRO-VAPOR MODEL



The ELECTRO-VAPOR series of deck ovens has been designed to combine the incredible power of our annular tube ovens with the flexibility of an electrical chamber with armored heating elements. This makes it possible to have advantage of the upper chamber at the end of working hours for the cooking of all those pastry products that require greater flexibility.

MAIN FEATURE: HYBRID OVEN (TUBES + ELECTRIC CHAMBER)





### ➤ ANULAR TUBES and QUALITY CONTROL

- The annular tubes are made of iron, diameter 35mm (or 27mm as an option), thickness 5.5mm;
- Each single tube is bent and welded manually in order to ensure perfect sealing over time;
- Each tube is tested with a special testing machine up to 600 atmospheres. High thickness tubes are the best choice to keep heat inside the oven as much as possible, avoiding falling down of temperature even after hours of stop.

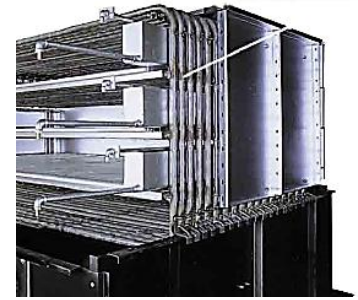

### ➤ BASEMENT



- the base of an ELECTRO VAPOR oven is the supporting base of the structure.
- We use high thickness iron, combined with strong and continuous welding, to guarantee maximum durability over time;
- The channels for the flue gas pass are entirely covered with refractory bricks created according to our exclusive recipe, with a composition that guarantees greater heat retention than the others on the market;
- The base is designed to be extremely easy to assemble, to save the assembly time as much as possible.

### ➤ DECKS AND COOKING

- Each tube is placed at a specific distance from each other to ensure perfect cooking.
- The resulting step comes from years of study and experience and is the secret of the entire structure.
- On each level outlined by the pipes, specific refractory bricks are placed to transfer the heat directly to the dough.
- The maximum cooking temperature is about 300 ° C. Above this threshold, the safety thermostat will stop the system.
- The oven increases its temperature by about 5 ° C every minute and in the morning, from cold starting, it will take about 50 minutes to reach the desired temperature.
- The upper chamber is ELECTRIC, independent from the rest of the oven both as power supply and as temperature regulation. It is equipped with armored heating elements and allows for unparalleled flexibility of use, aided by the heat generated by the other chambers, aimed at increasing the energy saving of the oven.

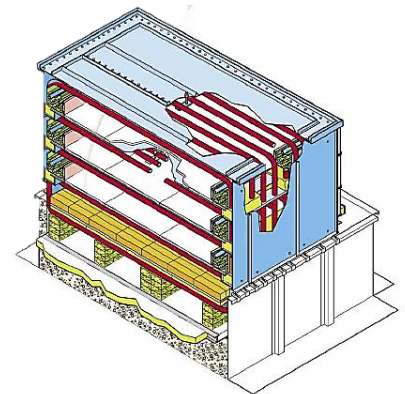

Our BRICKS are made with a specific and exclusive recipe, the result of years of experience, to ensure maximum heat retention with minimum dissipated energy. The advantage of this choice can be found in the reduction in consumption during the cooking cycle and in the constant color uniformity of the obtained bread.



## ➤ STEAMER

- Each chamber is equipped with 2 internal steel steam generators (right and left), unless otherwise requested at time of order.
- They are completely independent and guarantee a high and constant steam production;
- each steamer is easily removable for maintenance when and if necessary;
- the quantity of steam produced by the steam generators is related to the temperature used in the oven. If an average temperature of about 240°C is used, steam can be obtained for about 5 continuous seconds.

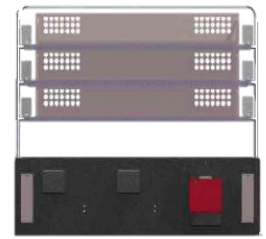

## ➤ GLASSES AND DOORS

Each oven can be customized with the number, type and size of doors.

- Available sizes: 615mm, 750mm;
- Available materials:
  - ✓ 100% glass with double 20mm chamber
  - ✓ Aisi 430 steel
- The opening can be upwards or downwards, depending on the model chosen.
- Each door is perfectly balanced.



### CONTROL PANEL:

- Standard electromechanical
- Touch screen on request
- 24V power supply



### POWER SUPPLY:

- Gas / oil burner
- Wood
- pellets



### OPTIONAL:

- Lateral furnace with wood

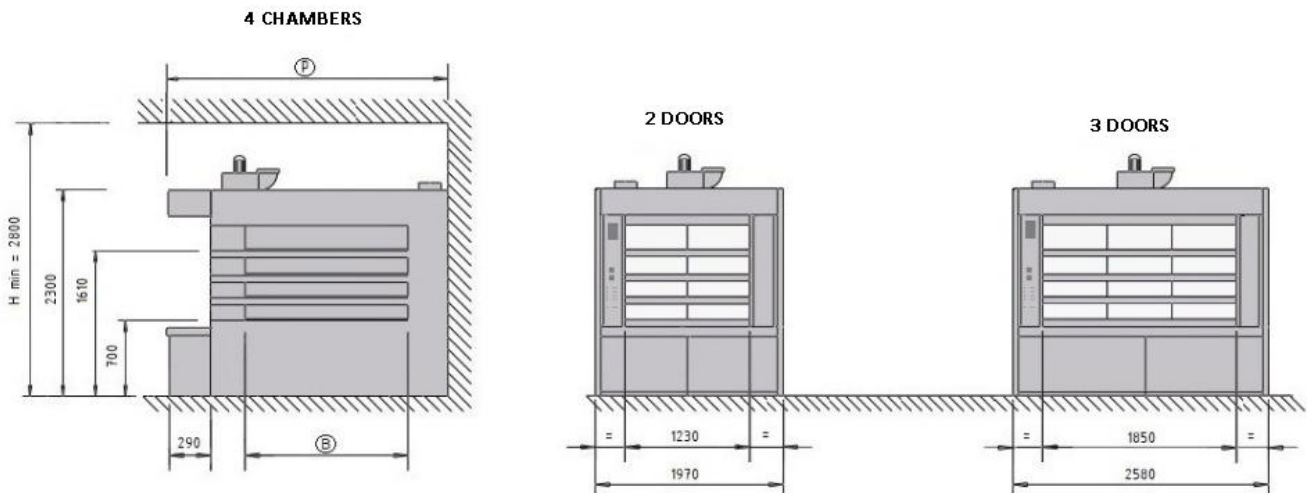

## TECHNICAL FEATURES «ELECTRO-VAPOR»

INFO	DECK TUBE OVEN WITH 1 ELECTRIC CHAMBER							
	FVE 42A	FVE 42C	FVE 42E	FVE 42G	FVE 43A	FVE 43C	FVE 43E	FVE 43G
N° anular tubes chambers	3	3	3	3	3	3	3	3
N° of sections	2	2	2	2	3	3	3	3
N° electric chamber	1	1	1	1	1	1	1	1
N° doors 62cm	8	8	8	8	12	12	12	12
Total cooking surface (m2)	8	10	11	12	12	15	16	18
Cooking surface tubes chambers (m2)	6	7,5	8,2	9	9	11,2	12	13,4
Cooking surface electric chamber (m2)	2	2,5	2,7	3	3	3,7	4	4,5
Internal chamber size (cm)	123x160	123x200	123x220	123x240	185x160	185x200	185x220	246x140
H 1° 2° 3° chambers (cm)	18	18	18	18	18	18	18	18
H 4° chamber (cm)	19	19	19	19	19	19	19	19
Doors opening (versus)	down	down	down	down	down	down	down	down
External size LxD (cm)	197x299	197x339	197x359	197x379	259x300	259x339	259x359	259x379
H tot no motors (cm)	230	230	230	230	230	230	230	230
H tot with motors (cm)	265	265	265	265	265	265	265	265
Approx. Weight (kg)	6.900	7.900	8.400	8.700	8.700	9.300	10.400	10.800
Tubes diameter (mm)	35x5,5	35x5,5	35x5,5	35x5,5	35x5,5	35x5,5	35x5,5	35x5,5
Thermal power kcal/h	55.000	60.000	64.000	70.000	70.000	85.000	90.000	95.000
Thermal power KW	58	70	74	81	81	99	104	110
Total electric power (KW)	9,4	10,9	11,6	12,3	13,1	15,4	16,5	17,7
Clay refractory decks	✓	✓	✓	✓	✓	✓	✓	✓
Structure material	Inox 430	Inox 430	Inox 430	Inox 430	Inox 430	Inox 430	Inox 430	Inox 430
Basement material	Iron	Iron	Iron	Iron	Iron	Iron	Iron	Iron
Pressed rock whool	✓	✓	✓	✓	✓	✓	✓	✓
Tempered glass	✓	✓	✓	✓	✓	✓	✓	✓
Chambers lighting	✓	✓	✓	✓	✓	✓	✓	✓
Steamer per chamber	2	2	2	2	2	2	2	2
Removable sprayers	✓	✓	✓	✓	✓	✓	✓	✓
Steam quantity	high	high	high	high	high	high	high	high

## CONVECTION OVEN SERIES

# «VENTO» MODEL



The VENTO series of convection ovens has been designed to combine the ease of cooking of convection ovens with the flexibility of use in all kind of field: bakery, pastry, gastronomy.

MAIN FEATURE: CONVECTION OVEN



## TECHNICAL FEATURES «VENTO»

INFO	CFC4 E	CFC4 G	CFC6 E	CFC6 G	CFC10 E	CFC10 G
Suitable for bread, pastry, gastro	✓	✓	✓	✓	✓	✓
Power supply	Electric	Gas	Electric	Gas	Electric	Gas
External Size (LxDxH) cm	85x103x70	85x103x70	85x103x85	85x103x85	85x103x113	85x103x113
Capacity (N° trays 40x60)	4	4	6	6	10	10
Space between shelves (mm)	80	80	80	80	80	80
Weight (kg)	93	93	110	123	140	160
Nominal Power (kw)	7,8	9,3	10,4	13,5	15,4	18
Tension	Electric 380/400 3N (V) - 50/60 hz	220/230 (V) – 50/60 hz	Electric 380/400 3N (V) - 50/60 hz	220/230 (V) – 50/60 hz	Electric 380/400 3N (V) - 50/60 hz	220/230 (V) – 50/60 hz
Temperature (°C)	100-270	100-260	100-270	100-260	100-270	100-260
Structure material	inox	inox	inox	inox	inox	inox
Control panel	Electromechanic	Electromechanic	Electromechanic	Electromechanic	Electromechanic	Electromechanic
Steamer	optional	optional	optional	optional	optional	optional
Touch screen (100 recipes)	optional	optional	optional	optional	optional	optional
Special probe	optional	optional	optional	optional	optional	optional
Washing system	optional	optional	optional	optional	optional	optional
Basement	optional	optional	optional	optional	optional	optional

Photos represent ovens with touch screen control panel



CFC4



CFC6



CFC10

# CUSTOMIZED TECHNICAL SOLUTIONS AND PLANT ENGINEERING

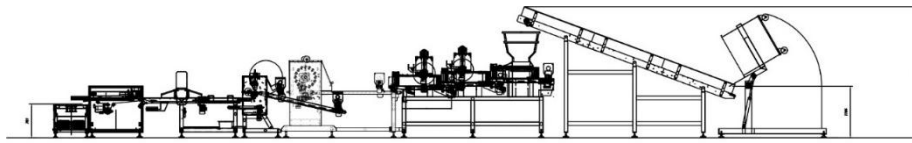

- LINES FOR BREAD
- LINES FOR CROISSANT
- LINES FOR PIZZA
- WORKING TABLES
- HANDLING SYSTEMS
- 100% CUSTOMIZED SOLUTIONS

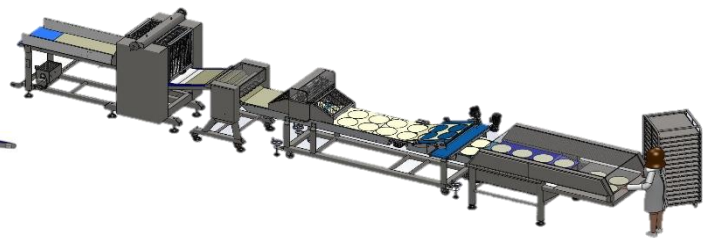
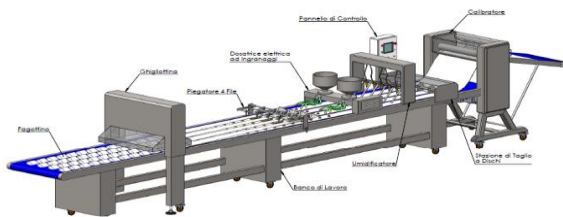
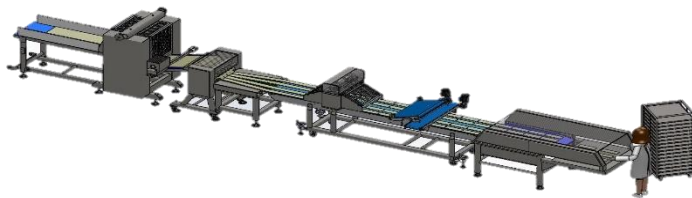



# EQUIPMENT AND MACHINES



### FLAT ALUMINIZED TRAYS THICKNESS 8/10

Code	Height (mm)	Size (mm)
CTLSP20402	20	200x400
CTLSP30402	20	300x400
CTLSP40602	20	400x600
CTLSP50702	20	500x700
CTLSP60802	20	600x800

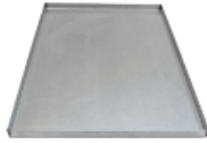

### FULL ALUMINIUM FLAT TRAYS THICKNESS 12/10

Code	Height (mm)	Size (mm)
CTAPP40602	20	400x600
CTAPP50702	20	500x700
CTAPP60802	20	600x800
CTAPP80802	20	800x800
CTAPP801002	20	800x1000



### PERFORATED ALUMINIUM FLAT TRAYS THICKNESS 15/10

Code	Height (mm)	Size (mm)
CTAFP40602	20	400x600
CTAFP50702	20	500x700
CTAFP60802	20	600x800
CTAFP80802	20	800x800
CTAFP801002	20	800x1000



### CORRUGATED PERFORATED ALUMINIUM TRAYS WITH 2 REINFORCEMENT BARS

Code	Height (mm)	Size (mm)	Rows
CTAFO4060	30	400x600	4-5
CTAFO5070	30	500x700	5-6
CTAFO6080	30	600x800	8-12
CTAFO8080	30	800x800	10-12
CTAFO80100	30	800x1000	10-14



### CORRUGATED PERFORATED ALUMINIUM TRAYS WITH 4 REINFORCEMENT BARS

Code	Height (mm)	Size (mm)	Rows
CTAFON4060	30	400x600	4-5
CTAFON5070	30	500x700	5-6
CTAFON6080	30	600x800	8-12
CTAFON8080	30	800x800	10-12
CTAFON80100	30	800x1000	10-14



### CORRUGATED PERFORATED ALUMINIUM TRAYS WITH SQUARED FRAME

Code	Height (mm)	Size (mm)	Rows
CTAFOT4060	30	400x600	4-5
CTAFOT5070	30	500x700	5-6
CTAFOT6080	30	600x800	8-12
CTAFOT8080	30	800x800	10-12
CTAFOT80100	30	800x1000	10-14



### CORRUGATED PERFORATED ALUMINIUM TRAYS WITH ROUNDED FRAME

Code	Height (mm)	Size (mm)	Rows
CTAFOS4060	20	400x600	4-5
CTAFOS5070	20	500x700	5-6
CTAFOS6080	20	600x800	8-12
CTAFOS8080	20	800x800	10-12
CTAFOS80100	20	800x1000	10-14



### ALUMINIZED TRAYS WITH SHAPES THICKNESS 8/10

Code	Size (mm)	Height	N° of shapes
CTLSF4060	400x600	15/25	On demand
CTLAF6080	600x800	15/25	On demand
CTLAF8080	800x800	15/25	On demand



### ALUMINIZED TINS THICKNESS 8/10 FOR TAST BREAD

Code	Size (mm)	height (mm)
CTLAPC2010H10	20X10	10
CTLAPC3010H10	30X10	10
CTLAPC4010H10	40X10	15
CTLAPC5010H10	50X10	15
Set/grups	On demand	On demand



Special and / or alternative measures "on demand"

**TROLLEYS FOR TRAYS**  
with galvanized wheel support

**Inox 430**

Code	Size
CCPTZ4060	400x600
CCPTZ5070	500x700
CCPTZ6080	600x800
CCPTZ8080	800x800
CCPTZ80100	800x1000



**TROLLEYS FOR TRAYS**  
with stainless steel wheel support

**Inox 304**

Code	Size
CCPTI4060	400x600
CCPTI5070	500x700
CCPTI6080	600x800
CCPTI8080	800x800
CCPTI80100	800x1000

**TROLLEYS FOR ROTOR**  
with galvanized wheel support

**Inox 430**

Code	Size
CCRZ4060	400x600
CCRZ5070	500x700
CCRZ6080	600x800
CCRZ8080	800x800
CCRZ80100	800x1000



**TROLLEYS FOR ROTOR**  
with stainless steel wheel support

**Inox 304**

Code	Size
CCRI4060	400x600
CCRI5070	500x700
CCRI6080	600x800
CCRI8080	800x800
CCRI80100	800x1000

**TROLLEY FOR TRAYS with pegs**

**Inox 304**

Code	Size
CPISTD	STD H 180
CPIDOUB	DOUBLE H 180



**RACK FOR LOADERS**

**Inox 304 / 580-590mm**

Code	Size
CPT2000	L: 2000 mm
CPT2500	L: 2500 mm
CPT3000	L: 3000 mm
CPT35000	L: 3500 mm



**MANUAL LOADERS**

**ALUMINUM + COTTON CANVAS**

Code	Roller center distance	Canvas width
	mm	mm
CT1600	1600	580
CT1800	1800	580
CT2000	2000	580
CT2200	2200	580
CT2400	2400	580
CT2800	2800	580
CT3200	3200	580

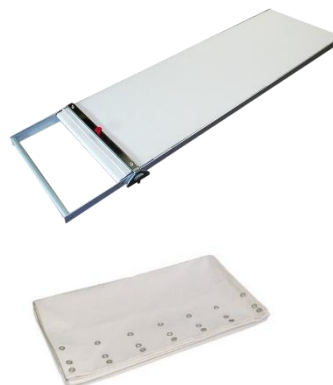

## LOADERS LIFTERS



Dimensions 94x250 height 190 cm,  
Empty weight 100KG,  
Baking size: from 61cm to 169cm  
Assembly: 1 hour



Dimensions depend on the oven  
Empty weight 300KG,  
Baking size: depends on the oven  
Assembly: 3 hours

## CONTROLLED FERMENTATION CHAMBER



### Main features:

- Anodized aluminum with interlocking structure
- 60mm polyurethane foam panels, with embossed aluminum coating
- Inox internal protections and channels
- Insulated and "temperature-controlled" basement to prevent water accumulation on the floor and in the walls
- Temperature range: -9 +45°C
- Refrigeration system with electrical impulse ventilation
- Injection steam generator
- Touch screen control with the possibility of "remote control"

CODE	DOORS	TROLLEYS	SIZE OF TROLLEYS	EXTERNAL SIZE	HEIGHT STD	POWER
	nr	nr	cm	mm	mm	kW
CFL124060	1	2	40X60	950X1110	2550	2,5
CFL244060	2	4	40X60	1350X1750	2550	7
CFL264060	2	5	40X60	1350X2150	2550	7
CFL126080	1	2	60X80	950X2150	2550	7
CFL246080	2	4	60X80	1750X2150	2550	7
CFL266080	2	6	60X80	1750X3000	2550	10
CFL286080	2	8	60X80	2150X3000	2550	13
CFL2480100	2	4	80X100	1750X2150	2550	7
CFL2680100	2	6	80X100	2150X3000	2550	13

## PROOFING CHAMBERS



### Main features:

- Anodized aluminum structure with interlocking panels
- 40mm polyurethane foam panels, with embossed aluminum coating
- Max Temperature: +45°C
- Inox internal protections and channels
- Electro mechanic/digital control panel
- Option: Touch screen control with the possibility of "remote control"

CODE	DOORS	TROLLEYS	SIZE OF TROLLEYS	EXTERNAL SIZE	HEIGHT STD	POWER
	nr	nr	cm	mm	mm	kW
C124060	1	2	40X60	840 x 1650	2250	3,5
C224060	2	2	40x60	1540 x 960	2250	3,5
C244060	2	4	40x60	1540 x 1650	2250	4,5
C264060	2	6	40x60	1540 x 2350	2250	4,5
C125070	1	2	50x70	840X1850	2250	3,5
C225070	2	2	50x70	1540X1060	2250	3,5
C245070	2	4	50x70	1540X1850	2250	4,5
C265070	2	6	50x70	1540X2650	2250	5,5
C126080	1	2	60x80	940X1970	2250	4,5
C226080	2	2	60x80	1800X1180	2250	4,5
C246080	2	4	60x80	1800X1970	2250	5,5
C266080	2	6	60x80	1800X2940	2250	6,5
C128080	1	2	80x80	1120X1970	2250	4,5
C228080	2	2	80x80	2070X1180	2250	4,5
C248080	2	4	80x80	2070X2000	2250	5,5
C268080	2	6	80x80	2070X2950	2250	6,5
C1280100	1	2	80x100	1120X2400	2250	4,5
C2280100	2	2	80x100	2070X1450	2250	4,5
C2480100	2	4	80x100	2070X2400	2250	6,5
C2680100	2	6	80x100	2070X3550	2250	6,5

## SPIRAL MIXERS

MODEL	CIS20	CIS30	CIS40	CIS60
Dough capacity (kg)	3-20	5-30	6-40	60
Spiral, column, tank	inox	inox	inox	inox
Dim. (cm) LxDxH	73x39x66	76x42x66	84x48x76	95x57x92
Weight (kg)	70	73	120	160
Power motor 3PH(Kw)	0,75/0,55	1,1/0,75	1,5/1,1	1,8/1,1
2 speeds	✓	✓	✓	✓
Chain transmission	✓	✓	✓	✓
Voltage, Hz, PH	400V, 50, 3	400V, 50, 3	400V, 50, 3	400V, 50, 3
Optional removable tank	✓	✓	x	x
Optional tilting head	✓	✓	✓	x



MODELLO	CIS80	CIS100	CIS130	CIS160	CIS200
Dough capacity (kg)	80	100	130	160	200
Flour capacity (kg)	50	65	80	100	125
Spiral, column, tank	inox	inox	inox	inox	inox
Dim. (cm) LxDxH	75x120x152	75x120x152	85x130x152	95x145x152	95x145x160
Weight (kg)	530	540	630	730	740
Power (Kw)	2,7 / 5,1	2,7 / 5,1	3,6 / 5,8	6,6 / 10	6,6 / 10
2 speeds	✓	✓	✓	✓	✓
Voltage, Hz, PH	400V, 50, 3	400V, 50, 3	400V, 50, 3	400V, 50, 3	400V, 50, 3



MODELLO	CISVE160	CISVE200
Dough capacity (kg)	160	200
Flour capacity (kg)	100	125
Spiral, column, tank	inox	inox
Dim. (cm) LxDxH	95x145x160	95x145x160
Weight (kg)	840	840
Power (Kw)	8,5	8,5
2 speeds	✓	✓
Voltage, Hz, PH	400V, 50, 3	400V, 50, 3



For CIS160 and CIS200 we have the possibility of adding the tipper on the bench or on the divider

## FORK MIXER

MODEL	CIF160
Dough capacity (kg)	160
Fork, tank	Alum/inox
Dim. (cm) LxDxH	106x151x135
Weight (kg)	120
Power motor 3PH(Kw)	5,5
2 speeds	✓
Chain transmission	✓
Voltage, Hz, PH	400V, 50, 3
Structure	Painted steel
Tank	Without motor (free)



## CUTTING MACHINE

### CUTTING MACHINE FOR TOAST BREAD

MODEL	CTTB	CTT
	BENCH	BASEMENT
Dimension (cm)	60x61x60cm	60x71x94cm
Weight (kg)	100	160
Structure	Painted steel	Painted steel
Power (kw)	0,75	0,75
Max length bread (cm)	42	52
H min/max bread (cm)	6/17	6/17
Blades distance (mm)	7-8-9-10-11-12-13-14-15-16-18-20	7-8-9-10-11-12-13-14-15-16-18-20



### CUTTING MACHINE FOR BAGUETTES

MODEL	CTB
	BENCH
Dimension (cm)	40x56x100cm
Weight (kg)	30
Structure	Painted steel
Power (kw)	0,18
Production (pcs/h)	8.000 – 16.000
Charging dimension (mm)	100x130
Cutting thickness (mm)	From 13 to 90mm







## DIVIDERS

### SEMI-AUTOMATIC DIVIDERS

RECTANGULAR TANK MODEL 	CSSAR10	CSSAR20	CSSAR24	CSSAR30	CSSAR40
N° divisions	10	20	24	30	40
Gr min (gr)	300	150	130	100	80
Gr max (gr)	2000	1000	830	660	500
Tank capacity (kg)	20	20	20	20	20
Dim. tank (mm)	100x200	100x100	100x80	80x84	50x100
Hourly capacity	1200	2400	2800	3600	4800
Dim. (cm) LxDxH	70x70x110	70x70x110	70x70x110	70x70x110	70x70x110
Voltage, Hz, PH	400V, 50, 3	400V, 50, 3	400V, 50, 3	400V, 50, 3	400V, 50, 3



HEXAGONAL TANK MODEL 	CSSAE19	CSSAE37
N° divisions	19	37
Gr min (gr)	90	30
Gr max (gr)	500	160
Tank capacity (kg)	9,5	6
Dim. tank (mm)	85	57
Hourly capacity	2300	4400
Dim. (cm) LxDxH	70x70x110	70x70x110
Voltage, Hz, PH	400V, 50, 3	400V, 50, 3

ROUNDED TANK MODEL 	CSSAT16	CSSAT20	CSSAT24
N° divisions	16	20	24
Gr min (gr)	190	150	130
Gr max (gr)	1200	1000	830
Tank capacity (kg)	20	20	20
Dim. tank (mm)	460	460	460
Hourly capacity	1900	2400	2800
Dim. (cm) LxDxH	70x70x110	70x70x110	70x70x110
Voltage, Hz, PH	400V, 50, 3	400V, 50, 3	400V, 50, 3

### SEMI-AUTOMATIC ROUNDERS - DIVIDERS

MODEL 	CSSAAR11	CSSAAR18	CSSAAR22	CSSAAR30	CSSAAR36
N° divisions	11	18	22	30	36
Gr min (gr)	180	120	60	40	34
Gr max (gr)	500	280	220	135	110
Tank capacity (kg)	5,5	5	5	4	4
Dim. tank (mm)	400	400	400	400	400
Hourly capacity	1300	2100	2600	3600	4300
Dim. (cm) LxDxH	75x80x145	75x80x145	75x80x145	75x80x145	75x80x145
Voltage, Hz, PH	400V, 50, 3	400V, 50, 3	400V, 50, 3	400V, 50, 3	400V, 50, 3



For the same models, a manual or fully automatic version is also available.

### MANUAL DIVIDERS ON DEMAND



## BAGUETTES MOULDER

MODEL	CB700
Cylinders (cm)	3 x 50 cm
Cylinder's opening (cm)	0-2
Dim. (cm) LxDxH	100x78x76
Weight (kg)	200
Power (Kw)	0,75
Pieces per hour (n°)	1200/1500
Maximum baguette length (mm)	790
Trolleys with wheels	✓
Painted steel structure	✓
Voltage, Hz, PH	400V, 50, 3



## MOULDER

MODEL	CF600
Cylinders (cm)	3 x 50 cm
Cylinder's opening (cm)	0-1
Dim. (cm) LxDxH	97x85x118
Weight (kg)	270
Power (Kw)	1,1
Dough (gr)	15-2500
Trolleys with wheels	✓
Painted steel structure	✓
Voltage, Hz, PH	400V, 50, 3



## PLANETARY MIXERS

MODEL	CPB10	CPB20	CPC40	CPC60	CPC80
Dim. (cm) LxDxH	58x68x83	58x68x83	70x100x150	80x105x157	80x105x157
Weight (kg)	90	90	375	375	375
Bowl capacity (L)	10	20	40	60	80
Control panel	variator	variator	3 speeds	3 speeds	3 speeds
Power (KW)	0,75	0,75	2,5	3	4
Structure material	Painted inox	Painted inox	Painted inox	Painted inox	Painted inox
Inox tools kit	✓	✓	✓	✓	✓
Tool's speed (rpm)	100-415	100-415	100-415	100-415	100-415
Option: speed variator	included	included	✓	✓	✓
Tension	220/380 50/60	220/380 50/60	220/380 50/60	220/380 50/60	220/380 50/60



Bowl reduction system on request

## DOUBLE ARM MIXER



MODEL	CT45	CT60	CT80	CT100	CT140	CT160
Dim LxDxH (cm)	64x98x146	77x118x163	77x118x163	95x140x186	95x140x186	95x140x186
Capacity dough (kg)	45	60	80	100	140	160
Power (Kw)	2,2	4	4	9,2	9,2	11
Tension	400 50 3	400 50 3	400 50 3	400 50 3	400 50 3	400 50 3
Weight (kg)	400	630	660	1000	1000	1000
2 Speeds rpm	31/62	31/62	31/62	31/62	31/62	31/62
Speed variator (option)	36 to 82	36 to 82	36 to 82	36 to 82	36 to 82	36 to 82
Inox tools	✓	✓	✓	✓	✓	✓
Structure material	Painted steel	Painted steel	Painted steel	Painted steel	Painted steel	Painted steel

Machine available with both electromechanical controls (2 speeds + timer) and touch screen

## SHEETERS



MODEL	CSBST58 SIMPLE	CSB58	CSB510	CS58	CS510	CS512
Belt width (cm)	X	50	50	50	50	50
Belt length (cm)	X	80	100	80	100	120
Basement	X	X	X	✓	✓	✓
Painted steel structure	✓	✓	✓	✓	✓	✓
Cylinder diameter (mm)	80	80	80	80	80	80
Max cylind. opening (mm)	30	45	45	45	45	45
Weight (kg)	80	130	140	210	220	230
Power (kw)	0,37	0,55	0,55	0,55	0,55	0,55
Pallet size(cm)	80x80x50	115x80x70	115x80x70	115x120x180	115x120x180	115x120x180
Voltage, Hz, PH	400V, 50, 3	400V, 50, 3	400V, 50, 3	400V, 50, 3	400V, 50, 3	400V, 50, 3

MODEL	CS610	CS612	CS614	CS616	CSA714 AUTOMATIC	CSA716 AUTOMATIC
Belt width (cm)	60	60	60	60	70	70
Belt length (cm)	100	120	140	160	140	160
Basement	✓	✓	✓	✓	✓	✓
Painted steel structure	✓	✓	✓	✓	Inox 304	Inox 304
Cylinder diameter (mm)	80	80	80	80	80	80
Max cylind. opening (mm)	45	45	45	45	45	45
Weight (kg)	240	250	240	250	650	680
Power (kw)	0,75	0,75	0,75	0,75	4,4	4,4
Pallet size(cm)	115x120x180	115x120x180	115x120x180	115x120x180	155x155x195	155x155x195
Voltage, Hz, PH	400V, 50, 3	400V, 50, 3	400V, 50, 3	400V, 50, 3	400V, 50, 3	400V, 50, 3
Cutting station available	X	✓	✓	✓	✓	✓

Automatic sheeters have touch screen control panel



## CROISSANT GROUP

MODEL	CGC3000	CGC6000
Ext. dimension (mm)	3000x2200	3000x2200
Weight (kg)	670	700
Power (kw)	2	2,2
Calibrator	✓	✓
Painted steel structure	✓	✓
Cylinder diameter (mm)	80	80
Tension	220/380 50/60	220/380 50/60
Hour/production	1800 pcs 100gr	3000 pcs 100gr
	2400 pcs 80gr	4000 pcs 80gr
	3000 pcs 50gr	5000 pcs 50gr
	3600 pcs 30gr	6000 pcs 30gr
	4000 pcs 20gr	7000 pcs 20gr

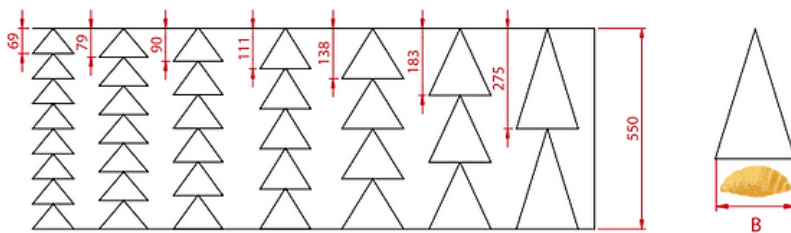

B = 68 - 75 - 90 - 100 - 110 - 120 - 130 - 140 - 150 - 160 - 170 - 180 - 180 - 190 - 200 - 240 - 300 (mm)

**Continental Forni srl**  
Via della tecnica 80  
36043 Camisano Vicentino  
Vicenza, Italia

Contatti:  
+39 3512729866  
[commerciale@continentalforni.com](mailto:commerciale@continentalforni.com)